

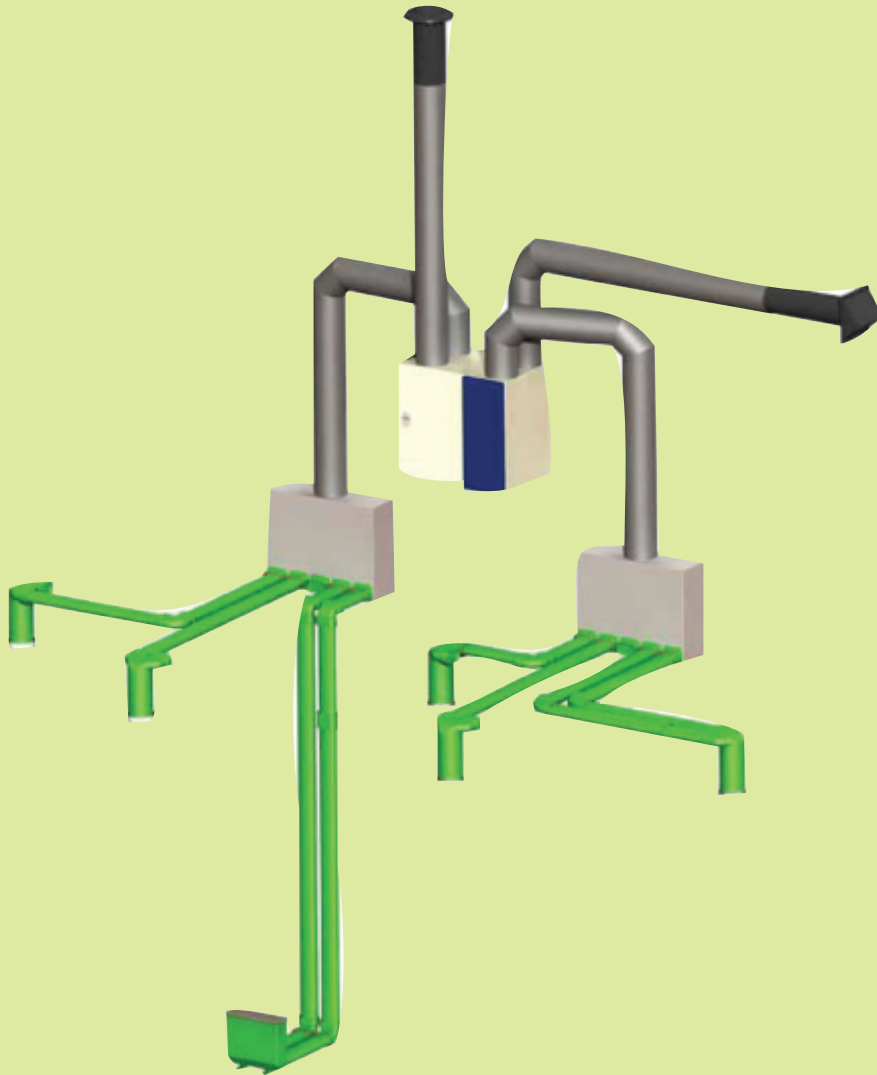

BRINK

Climate Systems



**Installation Manual
Low Profile Air
Excellent System**

Table of contents

Design	1	1
Serial production design	1.1	1
Composition of the air distribution system	1.2	2
Components	1.3	3
Air distributor	1.3.1	4
Distribution manifold components	1.3.2	4
Sealing ring	1.3.3	5
Orifice plate	1.3.4	5
Air distribution pipe	1.3.5	5
Snap connector	1.3.6	5
Pipe cap	1.3.7	6
Vertical bend 90°	1.3.8	6
Horizontal bend 90°	1.3.9	6
Connection for valve Ø125	1.3.10	6
Connection part of the floor grille	1.3.11	7
Supply air valve 125 mm	1.3.12	7
Exhaust air valve 125 mm	1.3.13	7
Floor grille 350 X 130 mm	1.3.14	7
Installation of the air delivery system	2	8
General	2	8
Installation of air distributor pipes to air distributor	2.1	8
Bends in air distribution system	2.2	10
Assembly of the floor grille or the supply / exhaust air valve	2.3	10
Change position of the air distribution pipe	2.4	11
Attention emphasis points on the connection of the pipe system	2.5	11
Air distributor	2.6	12
Pressure loss	3	13
Pressure loss low profile duct system – Air Excellent	3.1	13
Service	4	14
Service parts	4.1	14

1.1 Serial production design

The green plastic air distribution system is a newly designed product by Brink Climate Systems which is specifically intended for balanced ventilation, demand controlled ventilation or air conditioning with heat recovery. It is a modular system, which is composed of a flat channel, several accessories and an air distribution cabinet. The serrated flat canal is delivered in the size 50 x 100 mm and is suitable for an air volume flow rate of 30 – 35 m³ h with a flow velocity of about 3 m/s.

The flat channel can be processed easily and connected without special tools to the auxiliary components. The flat channel can be easily cut to length with a saw.

The flat channel and the accessories are supplied exclusively in green colour; exceptions are the seal rings and the air flux flow regulator, these are coloured red.

The plastic parts used are antistatic and antibacterial.

A program is made available by Brink, with which the values of orifice plates (number of rings which must be snipped off) can be determined in an easy way. A post facto adjustment of the orifice plates is time consuming, since the pipes must be decoupled once again for this. The orifice plates may only be fixed on the distribution cabinet connectors and not on the auxiliary parts.

An example which shows how all this functions is given in the calculating program. These assembly instructions shall not go into the function of the calculation program any further.

1.2 Composition of the air distribution system

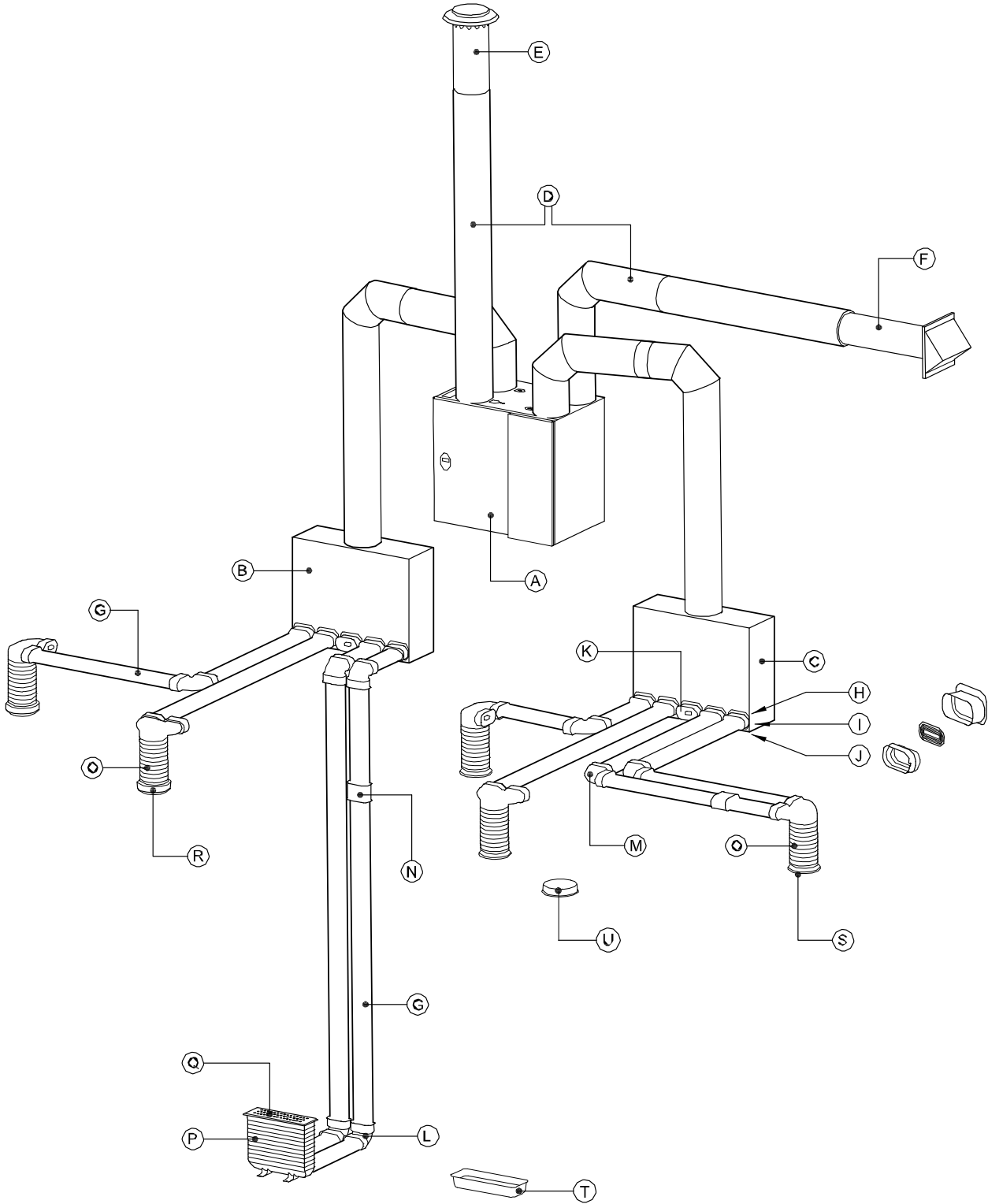

Example of layout of the air distribution system

6109-A

A	Brink Renovent	Brink heat recovery unit type Renovent
B	Fresh air distributor	Distribution cabinet, to which all air feed channels are coupled, see § 1.3.1
C	Exhaust air distributor	Distribution cabinet, to which all air exhaust channels are coupled, see § 1.3.1
D	Thermally insulated EPE pipe system	The thermally insulated EPE pipe system is used to connect the ceiling / roof or façade primary ducts to atmosphere and the air distributor to the Renovent HR. The use of this EPE pipe prevents the formation of condensate.
E	Exhaust / (fresh) air roof cowl	The ventilation air exhaust through the roof / ceiling. For fixing and / or the dimensions see the installation instructions sent regarding Renovent
F	Fresh air supply through the façade cowl	The inner side – insulated façade cowl, through which the clean exterior air is drawn in. For the fixing and / or the dimensions see the installation instructions sent regarding Renovent.
G	Flat low profile duct	The flat low profile air delivery piping in the size 50 X 100 mm, see section § 1.3.5
H	Distribution box connectors	The distribution manifold connectors are used for the connections of the air channels; a distribution manifold has 5, 10 or 15 distribution box connectors, see section § 1.3.2.
I	Orifice plate	The orifice plates are fixed in the distribution manifold at the assembled seal ring of the air distributor pipe which is ; by cutting through a ring or several rings, the air through flow can be adjusted, see section § 1.3.4.
J	Sealing ring	The sealing ring enables a good, air tight seal between the air distribution pipe and the other components of the air distribution system, see section § 1.3.3.
K	Duct cap	The duct cap is used for closing the connectors in the distributor manifold or in the floor gratings which are not being used, section § 1.4.7
L	90° vertical bend	The vertical bend is used to guide an air distributor pipe towards the top or the bottom, see section § 1.3.8.
M	90° horizontal bend	The horizontal bend is used to guide an air distributor pipe towards the right or the left, see section § 1.3.8.
N	Snap connector	Two plastic air distributor pipes can be connected to each other with a snap connector, see section § 1.3.6.
O	Connection part for valve	With an angle connection part, a supply air or exhaust air valve can be connected to the air distribution system, see section § 1.3.10.
P	Connection part floor grille	With a floor grille connection part, a floor grille can be connected to the air distribution system, see section § 1.3.11.
Q	Floor grille 350 X 130 mm	Floor grille; can be supplied in stainless steel or white epoxy coated, see section § 1.3.14
R	White PVC supply air valve Ø125	Through this white PVC supply air valve, fresh filtered air is supplied to the room, see section § 1.4.12.
S	White PVC exhaust air valve Ø125	Through this white PVC exhaust air valve, stale or contaminated air is extracted from the room, see section § 01.03.13.
T	Sealing duct dust cap to suit floor grille.	For each connection part of the floor grilles, one right angled duct dust cap is also supplied; this remains fitted on during the installation so that the air ducts do not get contaminated. Only when all construction work is completed is the floor grille fitted.
U	Sealing dust cap connection to suit valve Ø 125 mm	For each connection part of the floor gratings, one round pipe sealing cap Ø 125 mm is also supplied; this remains fitted on during the installation so that the air ducts do not get contaminated. Only when all construction work is completed, is the corresponding valve fixed.

1.3 Components

1.3.1 Air distributor (Manifold)

The air distributor is identical for both the supply air and the exhaust air. This air distributor is available in three models depending on the number of the air connectors required, that is with 5, 10 and 15 connections respectively. The connection diameter also varies with the model. The air distributors are manufactured from 1 mm zinc plated steel sheet and are insulated to minimise noise pollution.

Design

5 connectors
10 connectors
15 connectors

Connector diameter

Ø 125 mm holes
Ø 150 mm holes
Ø 180 mm holes

By exchanging the plate, on which the air distributor manifold connectors are fixed as well as the sealing cap of the air distributors, the arrangement of the air distributor can be adapted to the layout conditions on site, see section § 2.6.

An assembly kit is also included for the wall assembly, which among other things has four angle brackets; these can be screwed in a secure manner depending on the layout at the air distributor. The air distributor can be fixed to the wall

For dimensions of the air distributor see section § 2.6

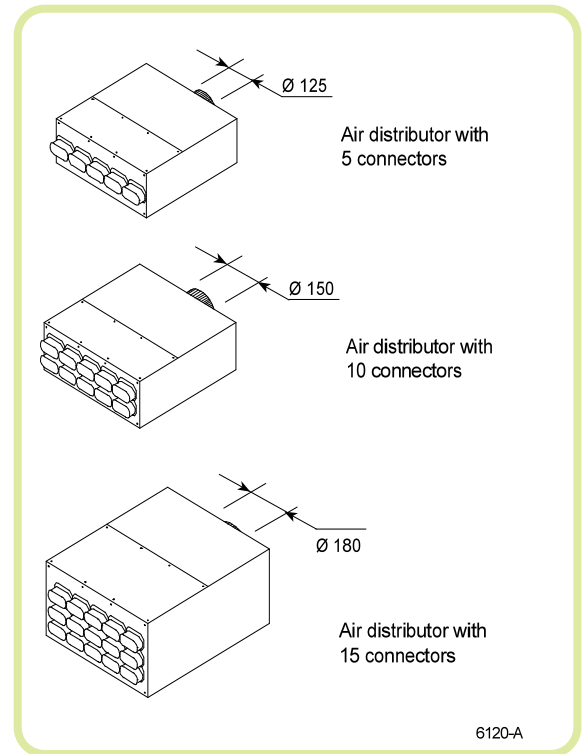

1.3.2 Distributor manifold connectors

At each air distributor connector there is a distributor manifold connector, to which an air pipe can be connected. Thus at an air distributor with 15 connectors, 15 distributor manifold connectors are assembled in the factory.

The distributor manifold connectors rest in the openings of the air distributor which are meant for them and are subsequently screwed tight.

If it is necessary to loosen an air distributor connector, this is possible by first removing the securing screw and lifting the corresponding distributor connector somewhat and thereupon pulling the distributor connector towards the front out of the opening of the distributor manifold. While fixing the distributor connector, it is to be pushed in and fixed down; subsequently it is to be screwed tight again.

For dimensions of the air distributor see section § 2.6

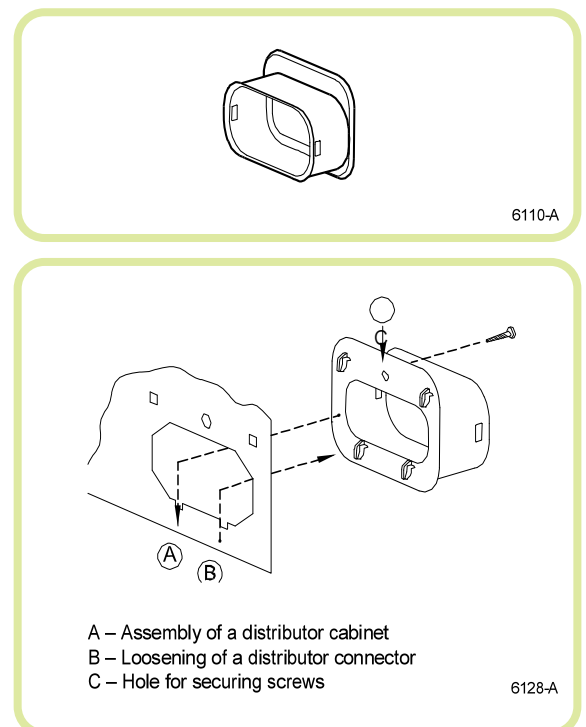

1.3.3 Sealing ring

In order to obtain an airtight seal between an air distributor manifold pipe and an air distributor or another component of the air distribution system, a sealing ring must be affixed at all places where an air distributor pipe is connected.

This sealing ring is first assembled on the air distributor connector and subsequently in the air distributor (if necessary provided with an orifice plate) or plugged into another component of the air distributor system. The assembly of this sealing ring in the air distributor pipe is only possible in one way (see for this section § 2.1); an air pipe with a sealing ring assembled can indeed be assembled rotated (see section § 2.4).



Sealing ring (pouch with 10 pieces)

6110-A

1.3.4 Orifice plate

An orifice plate can be used in order to adjust the air quantity to a valve or a grille. This is clamped to the sealing ring and subsequently pushed in together with the air distributor pipe in the air distributor manifold connector (see also section § 2.1).

The orifice plate is provided with 4 blowout rings; the higher the number of rings that are cut out, the greater the air quantity which is supplied to the grating or valve.

With the help of the Brink calculation program, it can be determined as to how much air must be supplied to each particular grille or valve and how many rings must be cut out from the orifice plate.



Orifice plate

6110-A

1.3.5 Air distribution pipe

With the flexible flat channel, the aeration air is forwarded from the air distributor onwards up to the grille or the valves as applicable. The flat sided pipe with the dimensions 50 x 100 mm is suitable for an air volume flux of 30 - 35 m³/h with a velocity of 3 m/s.

If more air is to be forwarded to a grille or valve, 2 adjacent pipes must be led to the grille or valve; the angle connection part of the floor grating or the connection of to the grille or valve is already fitted with a double barrel air connector (see also section §1.3.10 / section §1.3.11).

The air distributor pipe must always be fitted with the flat side to the wall or floor board as the case may be.

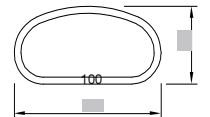
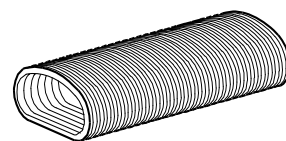

6110-A

Air distributor pipe (Roll 50 m)

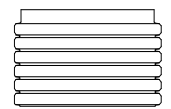

6125-A

1.3.6 Snap connector

A snap connector can be supplied for joining two air distributor pipes.

The flexible air pipe (including sealing rings) can be used on both sides of the flexible air pipe.

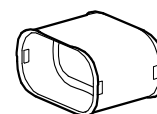

Snap connector

6110-A

1.3.7 Duct caps

The openings on the distributor manifold connectors (or angle connection parts of the floor grille) onto which no air distribution pipe are connected are to be closed with a duct cap (see also section §2.1).

While attaching the duct cap, no sealing ring needs to be fixed.

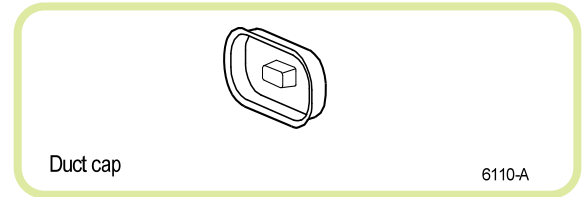

1.3.8 Vertical bend 90°

While the flexible air distribution pipe can be bent vertically, but due to the large radius which arises from this, it is recommended to use a vertical bend 90° for the purpose instead.

A flexible air pipe (including sealing rings) can be connected on both sides of this arc (see section §2.2).

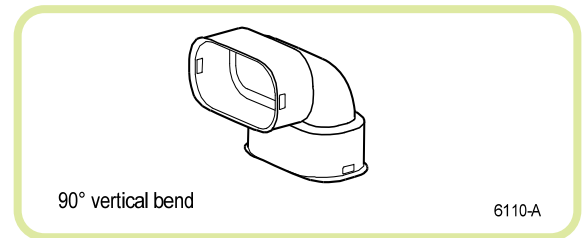

1.3.9 Horizontal bend 90°

The flexible air distribution pipe can be bent horizontally only very slightly; a horizontal bend 90° is to be used for this. A flexible air pipe (including sealing rings) can be connected on both sides of this arc (see section §2.2).

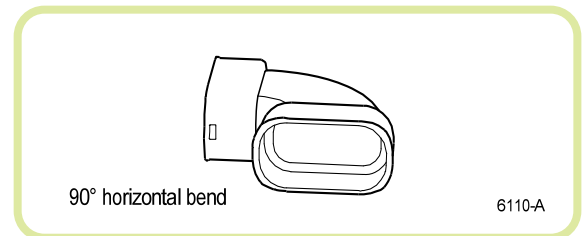

1.3.10 Connecting part for valve Ø125

This connecting part can be supplied in order to connect valves with a connection diameter of Ø125 mm. If the air volume coming out of the concerned valve is less than 30 m³/h, a single air pipe connector is sufficient; the other connector is to be closed with a duct cap in this case (see section §1.3.7). If the air volume coming out of the valve is between 30 and 60 m³/h, a second flexible air pipe must be connected to the connecting part. This connecting part for the valve is provided with a duct cap and is delivered mounted on one of the connectors.

If there is not enough space for the connecting part for valves, then it is possible to cut the round duct of Ø 125 diameter with the help of a saw. For the cut to be right-angled, (perpendicular to the pipe axis) auxiliary markings are provided on the whole length of the shaft.

See section §2.3 for an example of assembly

This connecting part for valves is supplied together with an assembled round duct cap 125 mm diameter. This cap is not to be removed during the installation period (if the shaft is cut to size, the cap is to be fixed anew). The valve desired is to be fixed only after completion of the construction work.

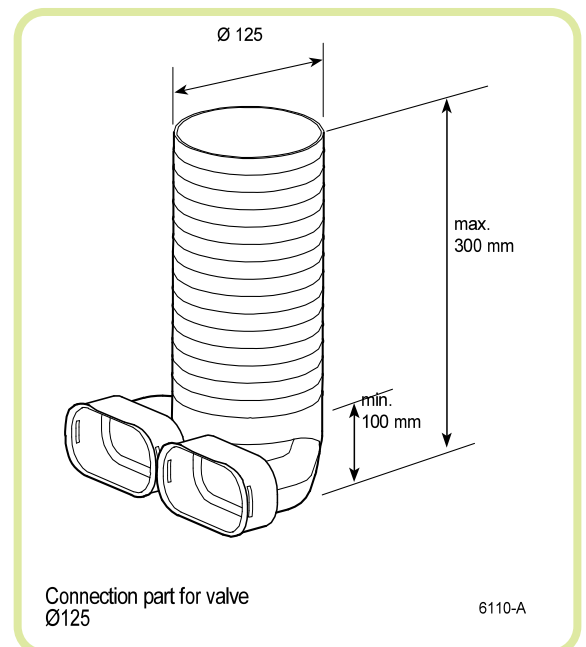

1.3.11 Connecting part of the floor grille

This connecting part can be supplied in order to connect the floor grille with the dimensions 350 X 130 mm (see section §1.3.14) to the air distribution system. If the air volume coming out of the concerned grille is less than 30 m³/h, a single air pipe connector is sufficient; the other connector is to be closed with a duct cap in this case (see section §1.3.7). If the air volume coming out of the grille is between 30 and 60 m³/h, a second flexible air pipe must be connected to the connecting part. This connecting part for floor grille is provided with a duct cap and is delivered mounted on one of the connectors.

If there is not enough space for the floor grille connecting part, then it is possible to cut the rectangular shaft to size with the help of a saw. In order that the cuts are right-angled, auxiliary markings are provided on the whole length of the shaft. The connecting part is provided with a flange on the reverse side, with which the connecting part can be affixed.

This connecting part is supplied along with an assembled duct cap. This cap is not to be removed during the installation period (if the shaft is cut to size, the cap is to be fixed anew).

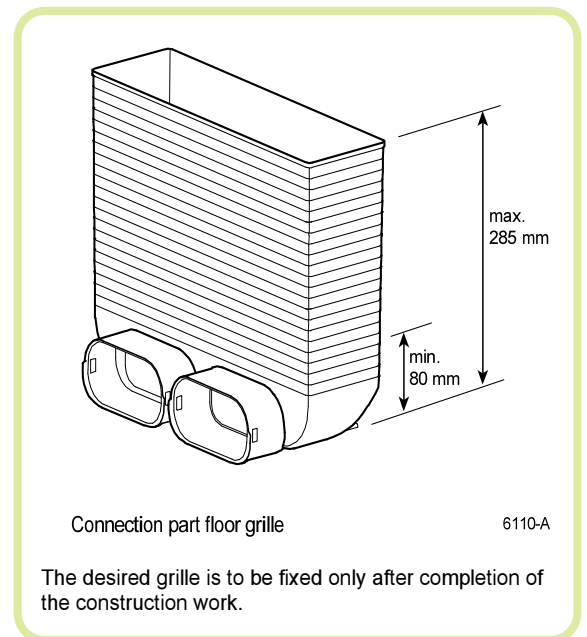

1.3.12 Supply air valve 125 mm

The highly induction white PVC air delivery valve (colour RAL9016) is provided with an up stand or mounting curb so that dirtying on the wall or ceiling is avoided.

A strip for a clean zone is delivered with this valve. The valve is provided with three stainless steel clamp springs and a rubber fixing ring for easy assembly. The supply air valve can be adjusted continuously (no steps – adjusting screw reached after detaching a round cap on the front side of the valve).

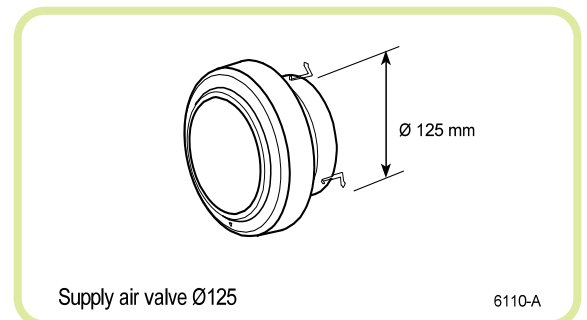

1.3.13 Exhaust air valve 125 mm

The white PVC exhaust air valve (colour RAL 9016) is especially suitable for humid enclosures. The valve is provided with three stainless steel clamp springs for easy assembly.

The disc of the exhaust air valve is adjustable in steps (for adjusting the disc, the securing safety clip is to be first removed from the back of the valve; subsequently the disc can be pushed in or pulled out; the securing clip is to be assembled back again after the adjustment).

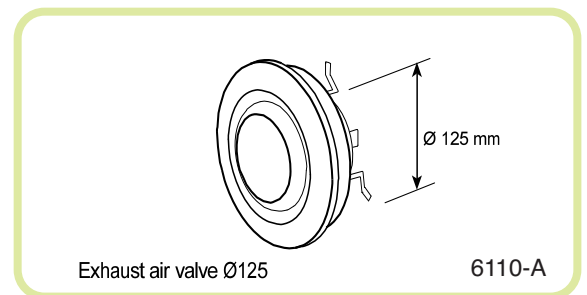

1.3.14 Floor grille 350 X 130 mm

This metallic supply air grille can be delivered in two versions, namely in white powder coated or stainless steel versions. This grille is clamped with two springs in the angle – angle connection part of the floor grille

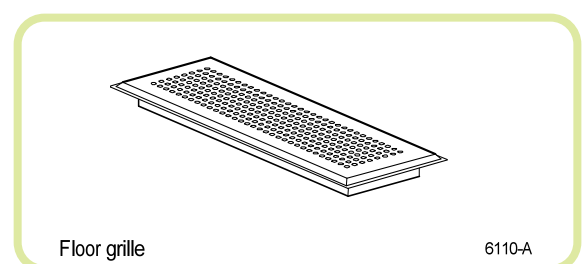

Installation of the air distributor system

2. General

Attention!

Always initially produce an outline with the aid of the calculation program!

Without these inputs it is not possible to install a well – functioning air distribution system.

2.1 Installation of air distributor pipes to air distributor

- 1 -

After laying the air distributor out in an easily accessible place, the necessary air pipes can be connected to it. Distributor manifold connectors to the air distributor which are not being used can be immediately closed with duct caps.

In order to avoid errors, it is sensible to mark the connectors suitably mark the air distributor connectors. The distributor manifold connectors have a flat side on which for example it can be marked with a water proof pencil as to which room the concerned pipe is leading and how large the corresponding air quantity should be.

- 2 -

The air distribution system can be easily cut to size with a saw; after the cutting to size; after cutting the pipes the inner sides are to be deburred.

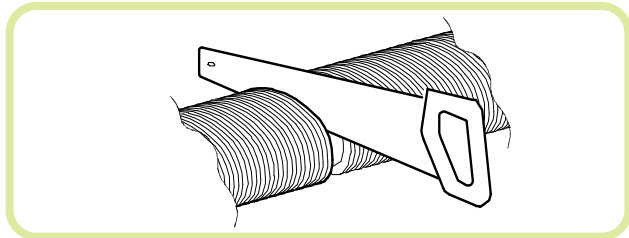

Please ensure that the air distributor pipes do not cross each other, and that they do not exceed the thickness of the floor or ceiling terminations.

- 3 -

Air distributor pipes which are connected to the air distributor, must be first provided with a sealing ring and (if necessary) an orifice plate. Push the sealing ring wide enough over the air distributor pipe, so that the 4 noses mounted on the inner side within the sealing ring are pushed fully over a ripple of the air distributor pipe and snap into place.

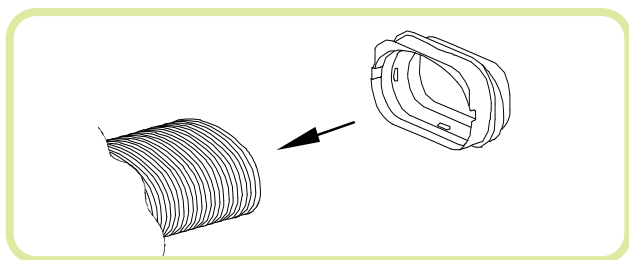

Remove the correct number of rings from the orifice plate according to the inputs from the calculation program. Subsequently, clamp the volume regulator tightly to the sealing ring and push together over the air distributor pipe.

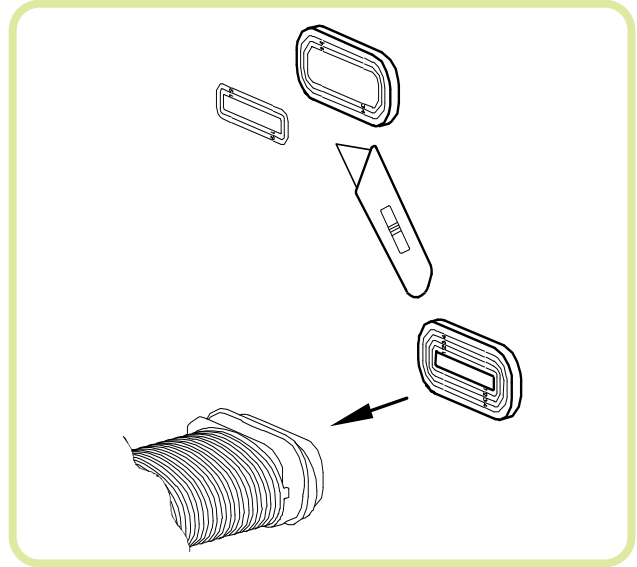

- 4 -

Connect the air distributor pipe including the previously assembled sealing ring to the appropriate distributor manifold connector. Both the outer side noses of the sealing ring must snap in properly into the openings of the distributor manifold connectors meant for them, so that the pipe sits securely.

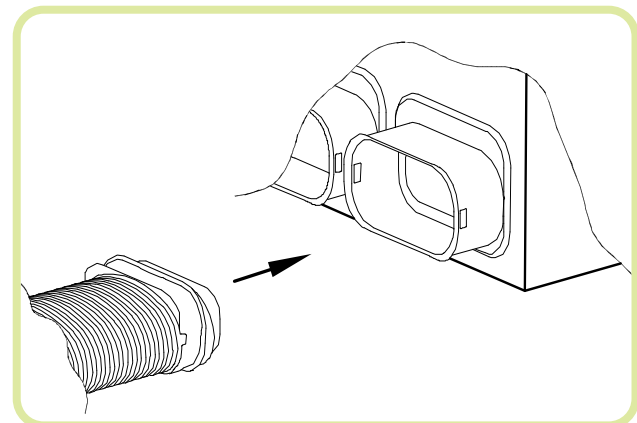

If it is necessary to remove the air distributor pipe from the air distributor, these two noses can be carefully pushed in with the help of a screwdriver and the pipe together with the sealing ring and orifice plates can be removed.

Installation of the air distributor system

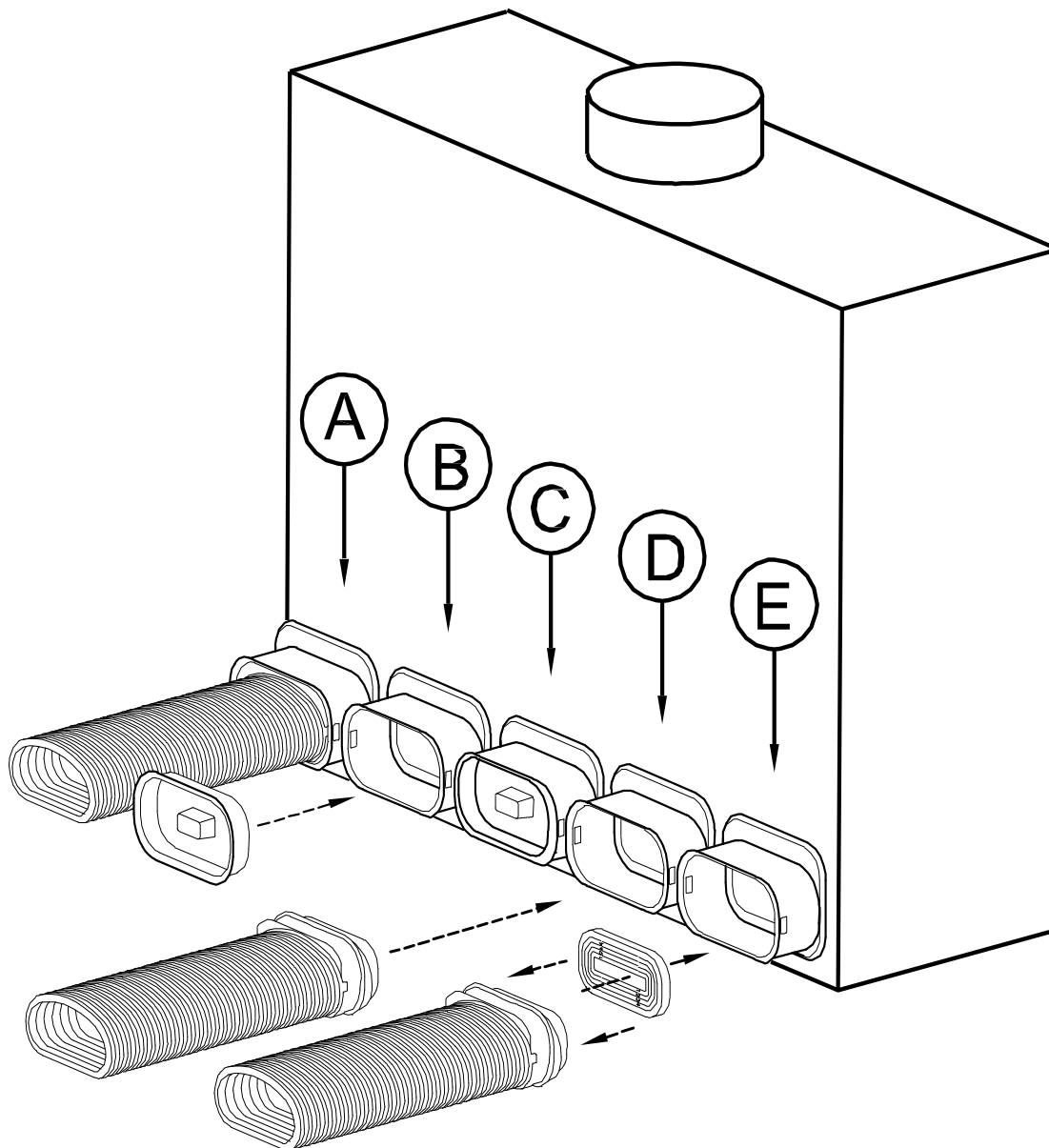

6124-A

- A = Air distributor pipe assembled on the air distributor
- B = Fit the duct cap on a distributor cabinet connector
- C = Duct cap fitted
- D = Assemble the air distribution pipe with sealing ring on the air distributor
- E = Assemble the air distribution pipe with orifice plates and sealing ring on the air distributor

Installation of the air distributor system

2.2 Bends in air distribution system

Two types of bends can be supplied in order to be able to guide an air distribution pipe to individual rooms, namely a horizontal and a vertical bend. A sealing ring is always to be used while connecting an air distribution pipe to a bend.

On both the bends, only an air distribution pipe can be connected

on both sides; it is not possible to connect other auxiliary parts directly to these bends. The air distribution pipes must always be mounted with the flat side towards the floor board or the wall as the case may be; the position of the sealing ring + pipe can be adjusted to the bends by turning the former by 180°.

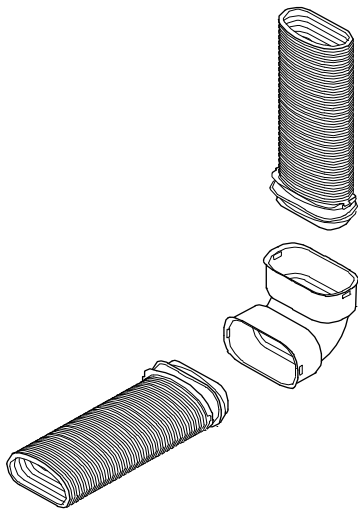

Vertical 90° Bend

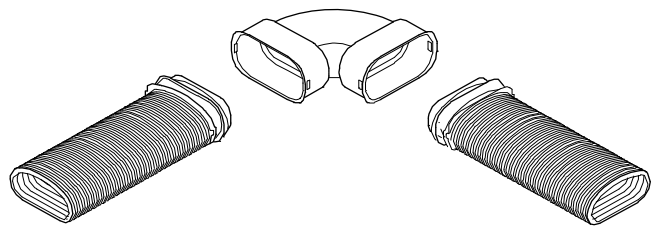

Horizontal 90° Bend

6126-A

2.3 Assembly of the floor grille or the supply or exhaust valves

Two types of bends can be supplied in order to be able to connect supply and exhaust valves or a grille as the case may be, two types of angle connecting parts can be supplied. A sealing ring is always to be used while connecting an air distribution pipe to an angle connecting part.

Only an air distribution pipe can be connected on both sides of the angle connecting part; connecting other auxiliary parts directly to these angle connecting parts is not possible. The position of the air distribution pipe can be adjusted to the angle connecting part / angle connecting part of the floor grille bends by turning the sealing ring + pipe by 180°.

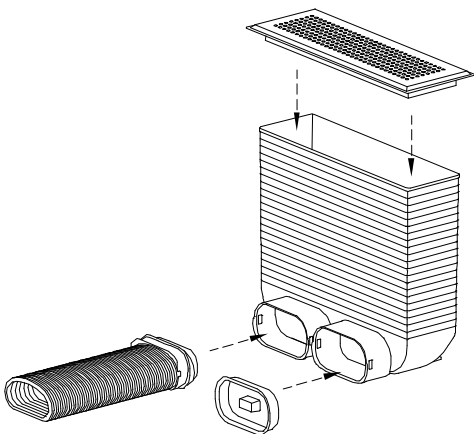

Right angled connection for the assembly of floor grille

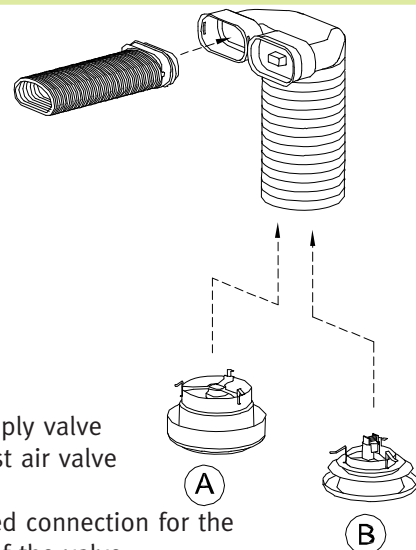

A = air supply valve
B = exhaust air valve

Right angled connection for the assembly of the valve

Installation of the air distributor system

2.4 Change position of the air distribution pipe

The position of the pipe can be turned towards auxiliary parts by turning the air distribution pipe together with the assembled sealing ring by 180° and subsequently inserting it in an auxiliary part, for example a bend.

In this way the plastic air distribution pipe can be set in different assembly situations with the same auxiliary parts, and in doing so the flat part of the pipe is always to be aligned against the wall or the ceiling as the case may be.

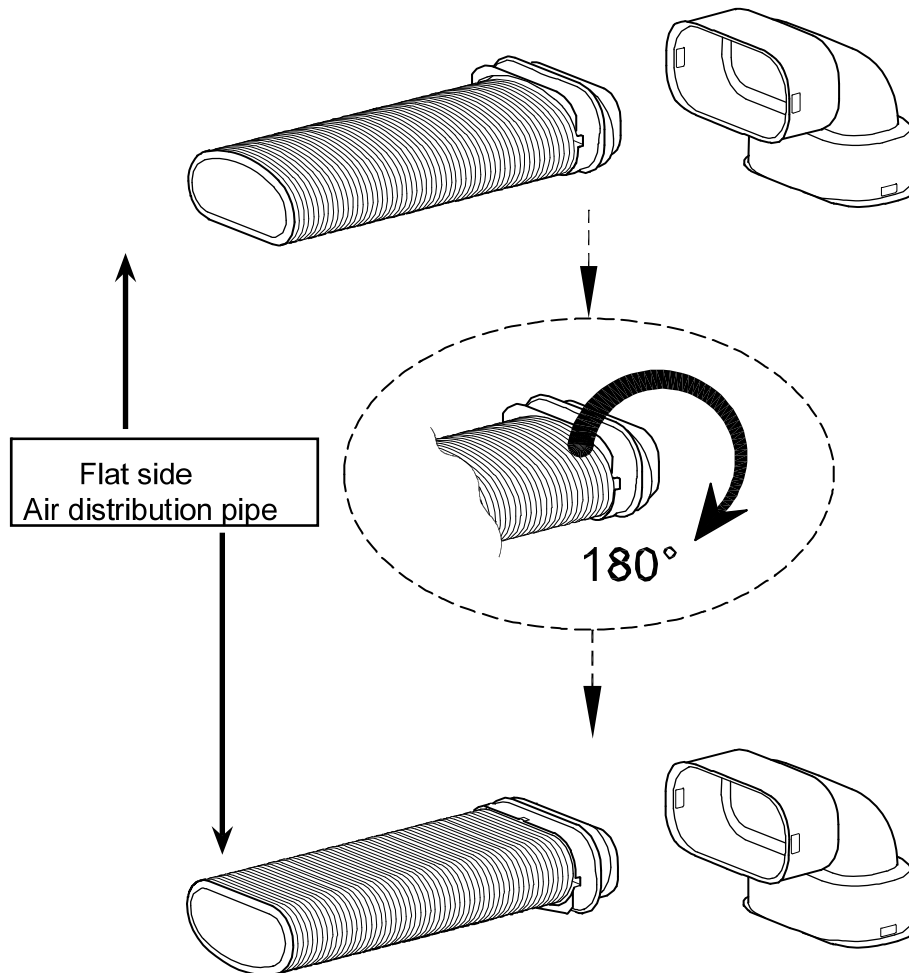

6132-A

2.5 Attention! Emphasis points on the connection of the pipe system air distributor

- Fire resistance:

Since all the parts of the air distributor system are throughout and consistently located in one single fire protection section, there is no specific requirement with regards to the fire breakdown or the overlapping and spreading into other rooms.

However if this air distribution system is used in high rise buildings, other measures could be taken in respect of fire retarding. This is possible for example by using fire protection cuffs or sleeves in the area of the wall / wall lead through.

- Cross talk noise:

Since every room to be air conditioned is connected with its own individual green PVC pipe or pipes, cross talk between the rooms is avoided. The distributor manifold is also sound proofed and provided with a sound damping section, so that the sound transfer through the distributor manifold is also avoided to the extent possible.

Installation of the air distributor system

2.6 Air distributors

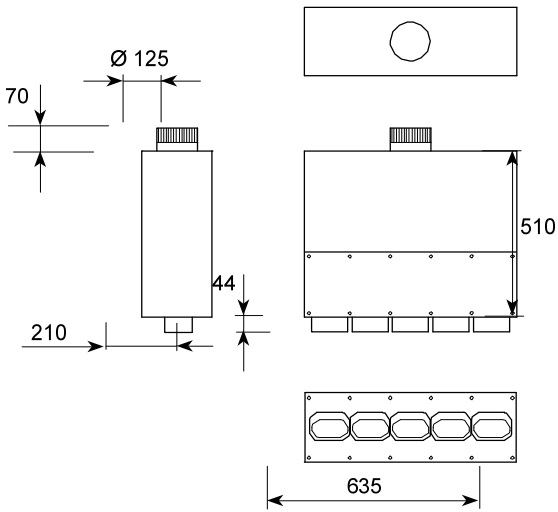

Delivery ex works: Air distributor with 5 connectors

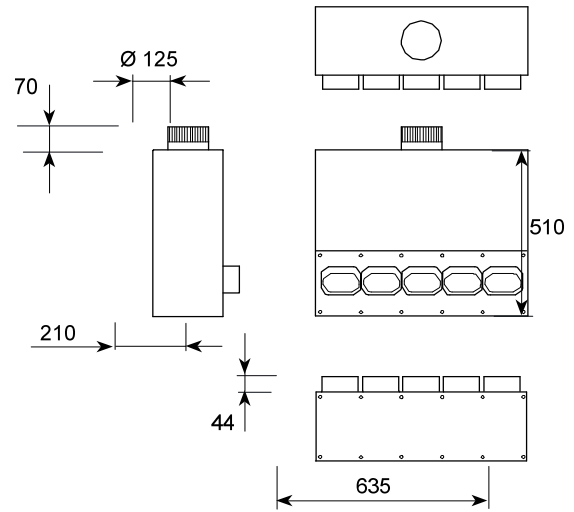

Air distributor with 5 transposed connectors

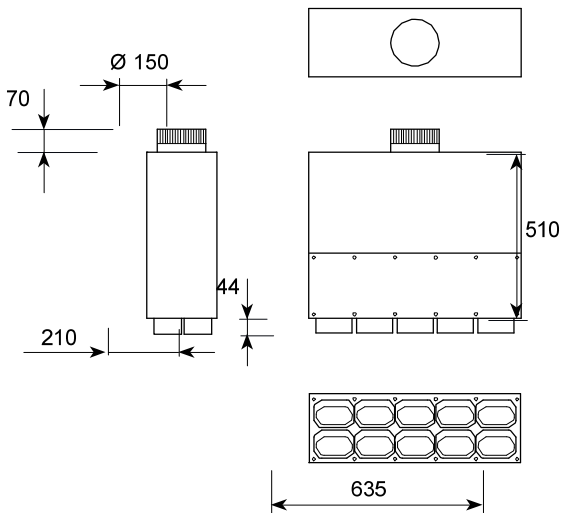

Delivery ex works: Air distributor with 10 connectors

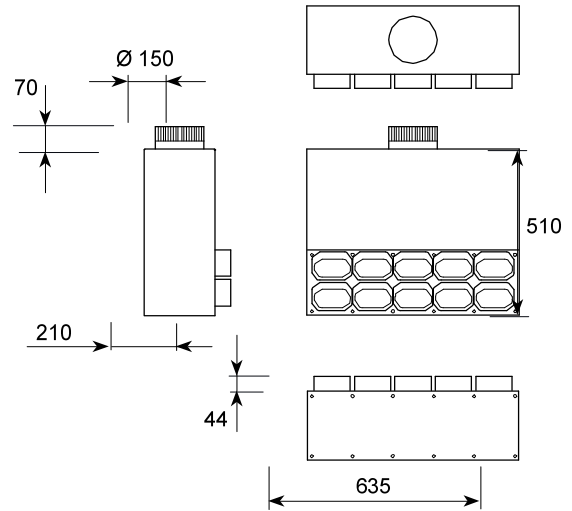

Air distributor with 10 transposed connectors

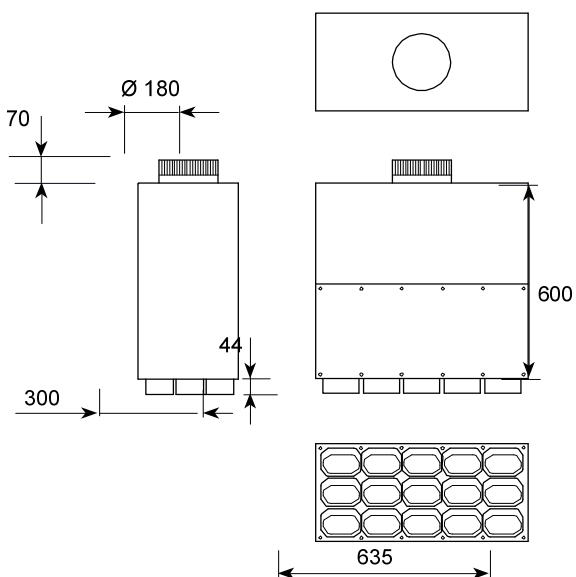

Delivery ex works: Air distributor with 15 connectors

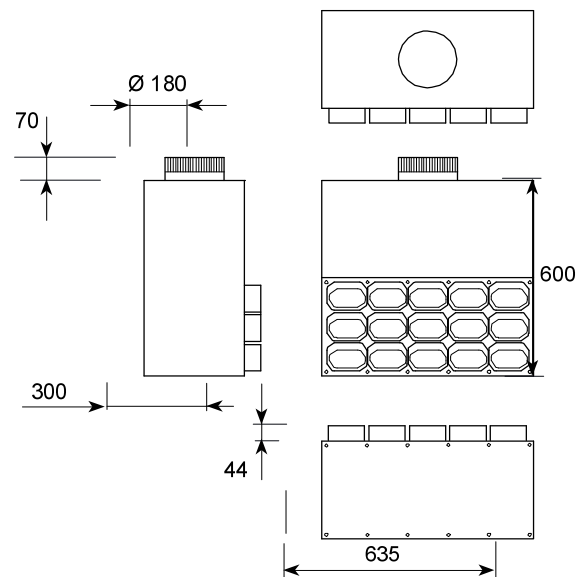

Air distributor with 15 transposed connectors

6130-A

3.1 Pressure losses in the Air Excellent Low Profile duct system

For determining the pressure loss, the most unfavourable pipeline run, i.e. usually the longest, is calculated first. The pipeline runs are calculated from entry (air delivery valve) or outlet (exhaust valve) of a room to the corresponding exterior air supply position or exhaust air outlet as applicable. All other lengths are shorter and have correspondingly lower pressure loss at the same volumes.

However it is not only the pressure losses over the lengths of the pipelines which is to be considered: there are also pressure losses at the bends and other parts which need to be taken into account. To ensure that the pre-determined quantities of air flow through the supply or exhaust air valves, the pipe lengths with the lower pressure losses must also be correspondingly curved or throttled. This is done by adjusting the corresponding air supply or exhaust valves.

Pressure losses Air Excellent Low Profile duct system:	Pressure losses in Pa with varying air volume											
	5	10	15	20	25	30	35	40	45	50	55	60
	m ³ /h	m ³ /h	m ³ /h	m ³ /h	m ³ /h	m ³ /h	m ³ /h	m ³ /h	m ³ /h	m ³ /h	m ³ /h	m ³ /h
Air distribution pipe 1 m long	0,1	0,3	0,8	1,3	2,1	3,0						
Vertical bend 90°	0,1	0,3	0,7	1,2	1,8	2,6						
Horizontal bend 90°	0,1	0,4	0,9	1,5	2,4	3,4						
Terminating part floor grille plenum with floor grille	0,1	0,4	0,9	1,7	2,6	3,8	3,3	4,3	5,4	6,7	8,1	9,7
Terminating part supply air valve - 25% open	0,9	3,5	7,8	13,8	21,6	31,1	45,9	59,9	75,8	93,6	113,3	134,8
Terminating part supply air - valve 100% open	0,2	0,9	2,1	3,8	5,9	8,5	9,0	11,8	14,8	18,4	22,3	26,5
Terminating part exhaust air valve - 25 % open	2,1	8,3	18,6	33,1	51,7	74,4	133,9	174,8	221,3	273,2	330,6	393,4
Terminating part exhaust air valve - 100 % open	0,6	2,2	5,0	8,9	13,9	20,0	15,2	19,9	25,2	31,1	37,6	44,8
Orifice plates – no ring is cut through	2,4	9,5	21,3	37,8	59,1	85,1						
Orifice plates – one ring is cut	0,6	2,5	5,7	10,1	15,8	22,8						
Orifice plates – ring 2 is out	0,2	0,7	1,7	3,0	4,7	6,7						
Orifice plates – ring 3 is out	0,1	0,2	0,5	0,9	1,4	2,0						
Orifice plates – ring 4 is out	0,0	0,1	0,3	0,4	0,7	1,0						

Attention! An air quantity of about 20 m³/h is recommended for the air distributor pipe for optimal operation. In case of larger volumes of air being required, two pipes are to be laid in parallel, by which the air quantity increases to about 40 m³/h.

Attention! Air volume greater than 50 m³/h can lead to flow noise at the valves.

4.1 Service parts

When an unscheduled part exchange becomes necessary, it is advisable to state the item code numbers, the article description and the number at the time of ordering.

Right to amend is reserved.
Brink Climate Systems B V always endeavours to improve its products and reserves the right to carry out amendments to the specifications without any prior notice.

Member of



Member of



Distributed by:



Ubbink (UK) Ltd, 81 Cherry Orchard Industrial Estate, Ballyfermot, Dublin 10.

Tel: 01 – 626 2600

Email: info@brinkclimatesystems.ie www.brinkclimatesystems.ie